

APPLICAZIONI

Elettropompe universali per applicazioni civili ed industriali, per impianti di lavaggio ad alta pressione, per l'irrigazione, l'agricoltura, impianti sportivi, per fontane e per movimentazione di liquidi moderatamente aggressivi privi di sostanze solide o abrasive.

APPLICATION

Universal pumps for domestic or municipal water supply systems, for clean non-explosive liquids without solid or abrasive substances, for agricultural irrigation and sports application, for civil and industrial use, boiler feeding and condensate systems and for high pressure washing plants.

LIMITI D'IMPIEGO

- Temperatura liquido fino a 35°C (per un uso domestico secondo EN 60335-2-41)
- Temperatura max. liquido: 110°C (per altri impieghi)
- Temperatura ambiente fino a 40° C

MOTORE

- Monofase 230V-50Hz
- Trifase 230/400V-50Hz
- Motore elettrico ad induzione a 2 poli (n = 2900 min⁻¹)
- Isolamento Classe F
- Protezione IP 55

MATERIALI

- Corpo aspirazione Acciaio Inox AISI 304
- Corpo mandata Acciaio Inox AISI 304
- Girante Acciaio Inox AISI 304
- Camicia pompa Acciaio Inox AISI 304
- Coperchio superiore Acciaio Inox AISI 304
- Coperchio inferiore Acciaio Inox AISI 304
- Albero motore Acciaio Inox AISI 304
- Tenute meccaniche Silicio/Silicio/Viton

OPERATING CONDITIONS

- Liquid temperature up to 35°C (for home use according to EN 60335-2-41)
- Temperature max. liquid: 110°C (for other uses)
- Ambient temperature max to 40°C

MOTOR

- Single-phase 230V-50Hz
- Three-phase 230/400V-50Hz
- Two-pole electric standard motor (n = 2900 min⁻¹)
- Insulation Class F
- Protection IP 55

MATERIALS

- Suction casing Stainless Steel AISI 304
- Delivery casing Stainless Steel AISI 304
- Impeller Stainless Steel AISI 304
- External jacket Stainless Steel AISI 304
- Upper cover Stainless Steel AISI 304
- Lower cover Stainless Steel AISI 304
- Pump shaft Stainless Steel AISI 304
- Mechanical seal Silicon/Silicon/Viton



TIPO TYPE		POTENZA NOMINALE NOMINAL POWER		AMPERE		Q = PORTATA - CAPACITY										
Monofase Single-phase	Trifase Three-phase	P2		Monofase Single-phase	Trifase Three-phase	Prevalenza manometrica totale in m.C.A. - Total head in meters w.c.										
		HP	kW			m³/h	1,5	2	2,4	3	3,5	4	5	6	7	8
						lt/1'	25	33	40	50	58	66	83	100	116	133
						H (m)	28	27	26,5	25,5	24,5	23,5	21	18	14	10
VSM 4-3	VS 4-3	0,75	0,55	3,4	1,4		38	36	35,5	34,5	33,5	32	29	24,5	19	13
VSM 4-4	VS 4-4	1	0,75	5	1,7		56	54,5	53,5	52	50	48	42	36	28,5	20
VSM 4-6	VS 4-6	1,5	1,1	6,9	2,5		74	73	72	70	68	66	60	52	42	27
VSM 4-8	VS 4-8	2	1,5	9,7	3,5		114	110	107,5	104	101	96	87	74	59	41
VSM 4-12	VS 4-12	3	2,2	13,5	4,7		152	149,5	146,5	142	137	131,5	118	101	80	55
	VS 4-16	4	3		6,1		183	179	175	168	163	158	143	124	100	67
	VS 4-19	5,5	4		8		211	205	200	194	188	181	164	142	116	79
	VS 4-22	5,5	4		8											

VERTICAL MULTISTAGE STAINLESS STEEL PUMPS

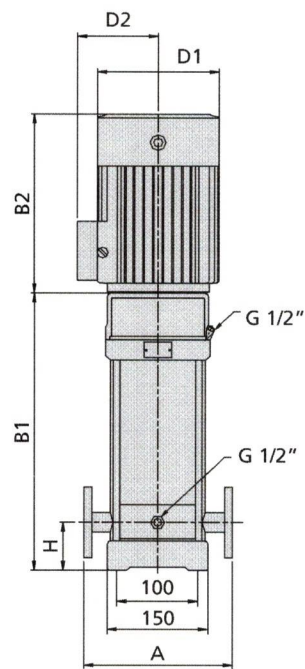
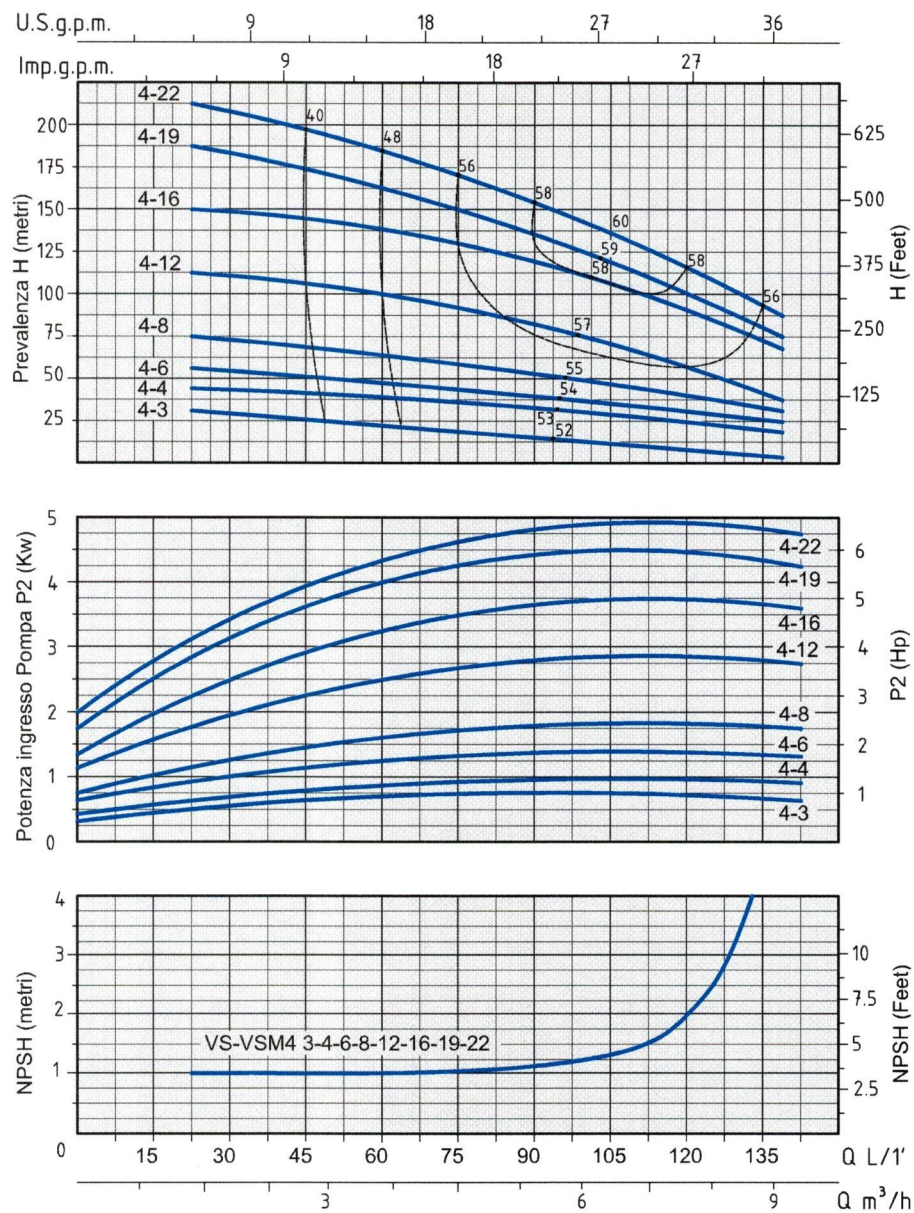

DN 32 1" 1/4

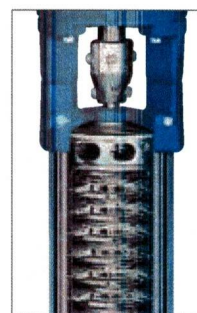
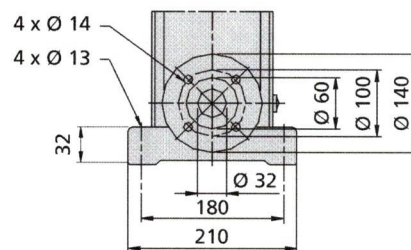

TIPO TYPE		DIMENSIONI mm - DIMENSIONS mm							DIMENSIONI DIMENSIONS mm			PESO WEIGHT	
Monofase Single-phase	Trifase Three-phase	A	H	B1	B2	B1 + B2	D1	D2	FLANGIA FLANGE	P	L	H	Kg
VSM 4-3	VS 4-3	250	75	303	210	513	148	148	DN 32 1" 1/4	320	765	395	37,1
VSM 4-4	VS 4-4	250	75	340	245	585	170	142	DN 32 1" 1/4	320	765	395	39
VSM 4-6	VS 4-6	250	75	394	245	639	170	142	DN 32 1" 1/4	320	765	395	44,1
VSM 4-8	VS 4-8	250	75	458	290	748	190	155	DN 32 1" 1/4	372	965	445	52,1
VSM 4-12	VS 4-12	250	75	566	290	856	190	155	DN 32 1" 1/4	372	965	445	57,1
	VS 4-16	250	75	684	315	999	197	165	DN 32 1" 1/4	365	1115	440	64,1
	VS 4-19	250	75	765	335	1100	230	188	DN 32 1" 1/4	417	1215	445	78,5
	VS 4-22	250	75	846	335	1181	230	188	DN 32 1" 1/4	417	1215	445	81,8